

Description

The LC03-6-L transient voltage suppressor is designed to protect components which are connected to high speed telecommunication lines from voltage surges caused by lightning, electrostatic discharge(ESD), cable discharge events (CDE), and electrical fast transients(EFT). TVS diodes are ideal for use as board level protection of sensitive semiconductor components. The LC03-6-L combines a TVS diode with a rectifier bridge to provide transient protection in both common and differential mode with a single device. The capacitance of the device is minimized (<25pF) to ensure correct signal transmission on high speed lines. The LC03-6-L meets the short-haul (intra-building) transient immunity requirements of Bellcore 1089 for telecommunications applications. The SO-8 surface mount package allows flexibility in the design of crowded PC boards.

Features

- ◆ 280W peak pulse power(8/20μs)
- ◆ Complies with following standards:
 - IEC 61000-4-2 (ESD) immunity test
 - Air discharge: ±15kV
 - Contact discharge: ±8kV
 - IEC61000-4-5 (Lightning) 19A (8/20μs)
- ◆ Protects two lines in common and differential mode
- ◆ Low capacitance for high-speed interfaces
- ◆ Low clamping and operating voltage
- ◆ Integrated structure saves board space and Increases reliability
- ◆ Solid-state EPD technology

Mechanical Characteristics

- ◆ JEDEC SO-8 package
- ◆ ROHS/WEEE Compliant
- ◆ Molding compound flammability rating: UL 94V-0
- ◆ Marking: Part number, date code
- ◆ Packaging: Tube or Tape and Reel per EIA 481

Applications

- ◆ T1/E1 Line Cards
- ◆ T3/E3 and DS3 Interfaces
- ◆ STS-1 Interfaces
- ◆ ISDN S/T-Interfaces
- ◆ ISDN U-Interfaces
- ◆ 10/100/1000 Ethernet

Dimensions and Pin Configuration

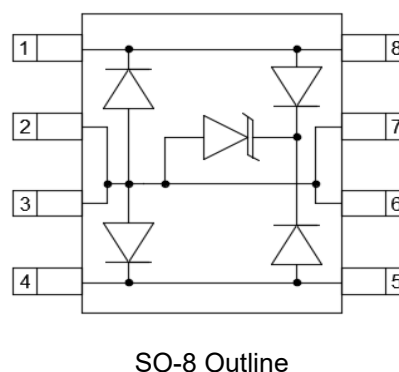
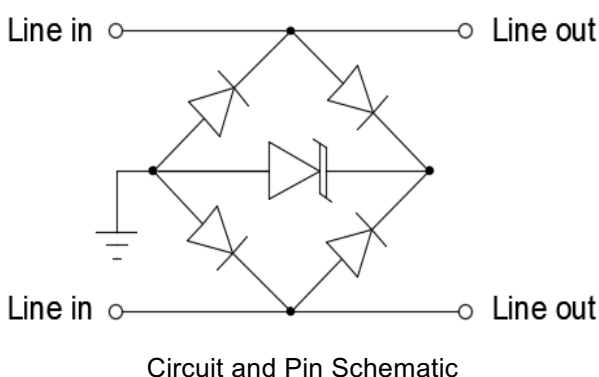

Ordering Information

Part Number	Marking	Packaging	Reel Size
LC03-6-L	SC YYXX LC03-6-L	2500/Tape & Reel	13 inch

Absolute Maximum Ratings ($T_A=25^{\circ}\text{C}$ unless otherwise specified)

Parameter	Symbol	Value	Unit
Peak Pulse Power(8/20 μs)	Ppk	280	W
Peak Pulse Current(8/20 μs)	I _{PP}	19	A
Lead Soldering Temperature	T _L	260(10 sec.)	$^{\circ}\text{C}$
Operating Temperature Range	T _J	-55 to +125	$^{\circ}\text{C}$
Storage Temperature Range	T _{stg}	-55 to +150	$^{\circ}\text{C}$

Electrical Characteristics ($T_A=25^{\circ}\text{C}$ unless otherwise specified)

Parameter	Symbol	Min	Typ	Max	Unit	Test Condition
Reverse Working Voltage	V _{RWM}			5	V	
Reverse Breakdown Voltage	V _{BR}	6		8	V	I _T = 1mA
Reverse Leakage Current	I _R			0.5	μA	V _{RWM} = 5V, T=25 $^{\circ}\text{C}$
Clamping Voltage	V _C		8.5		V	I _{PP} = 1A (8 x 20 μs pulse) Line to Ground
Clamping Voltage	V _C		13		V	I _{PP} = 10A (8 x 20 μs pulse) Line to Ground
Clamping Voltage	V _C		15.5		V	I _{PP} = 19A (8 x 20 μs pulse) Line to Ground
Junction Capacitance	C _J		1.5		pF	V _R = 0V, f = 1MHz Between I/O pins and Ground
			0.7		pF	V _R = 0V, f = 1MHz Between I/O pins

Typical Performance Characteristics ($T_A=25^\circ\text{C}$ unless otherwise Specified)

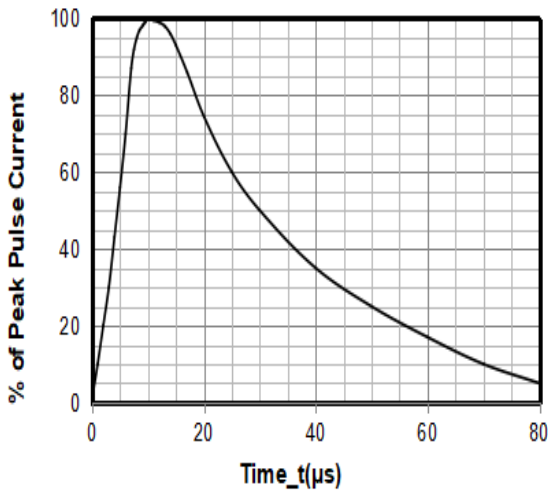

8 X 20μs Pulse Waveform

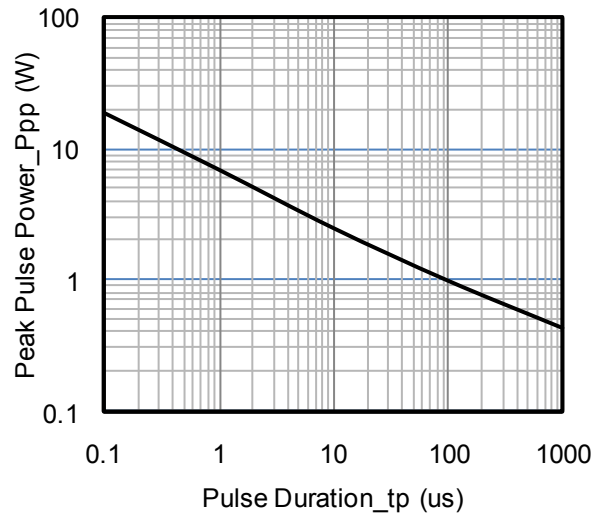

Peak Pulse Power vs. Pulse Time

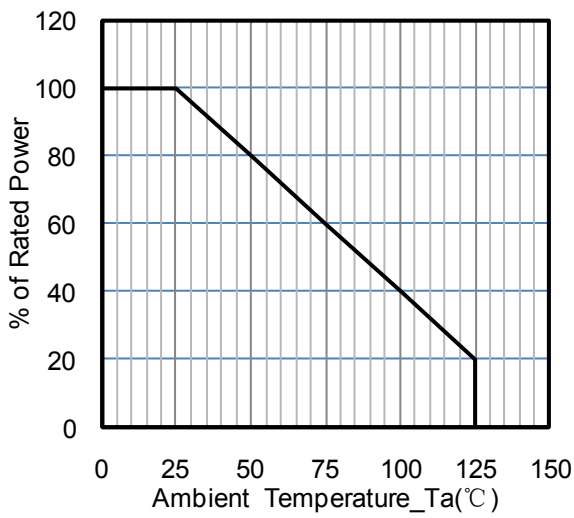

Power Derating Curve

Applications Information

Device Connection Options for Protection of Two High-Speed Data Lines

The LC03-6-L is designed to protect two high-speed data lines (one differential pair) from transient over-voltages which result from lightning and ESD. The device can be configured to protect in differential (Line-to-line) and common (Line-to-Ground) mode. Data line inputs/outputs are connected at pins 1 to 8, and 4 to 5 as shown. Pins 2, 3, 6 and 7 are connected to ground. These pins should be connected directly to a ground plane on the board for best results. The path length is kept as short as possible to minimize parasitic inductance. In application where high common mode voltage are present, differential protection is achieved by leaving pins 2, 3, 6 and 7 not connected.

T1/E1 Linecard Protection (Intra-Building)

A typical T1/E1 linecard protection circuit is shown below. The LC03-6-L is connected between Tip and Ring protection to metallic and common mode lightning surges per Bellcore 1089. This design takes advantage of the isolation of the transformer to suppress common mode surge. To complete the protection circuit, the Rclamp3304N (or Rclamp0504N for 5V supplies) is employed as the IC side protection element. This device helps prevent the transceiver from latching up by providing fine clamping of transients that are coupled through the transformer.

T3/E3 and STS-1 Protection

The LC03-6-L can also be used to protect T3/E3 and STS-1 interfaces. The data lines from the BNC interface are run through the LC03-6-L (i.e. enter at pin 1 and exits at pin 8) with the ground connection made at the other side of the device (pins 4 and 5). The center pins (2, 3, 6, and 7) are not connected. In this configuration, the LC03-6-L adds less than 12pF of capacitance to each line and provides surge protection to 100A ($t_p=8/20\mu s$)

Matte Tin Lead Finish

Matte tin has become the industry standard lead-free replacement for SnPb lead finishes. A matte tin finish is composed of 100% tin solder with large grains. Since the solder volume on the leads is small compared to the solder paste volume that is placed on the land pattern of the PCB, the reflow profile will be determined by the requirements of the solder paste. Therefore, these devices are compatible with both lead-free and SnPb assembly techniques. In addition, unlike other lead-free compositions, matte tin does not have any added alloys that cause degradation of the solder joint.

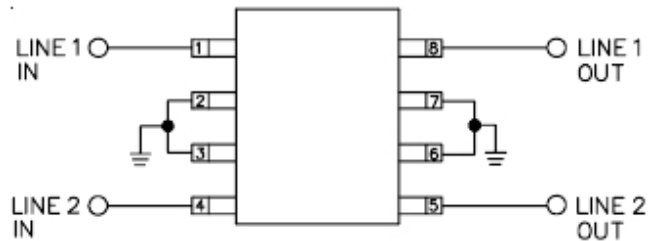

Connection for Differential (Line-to-Line) and Common Mode Protection (Line-to-Ground)

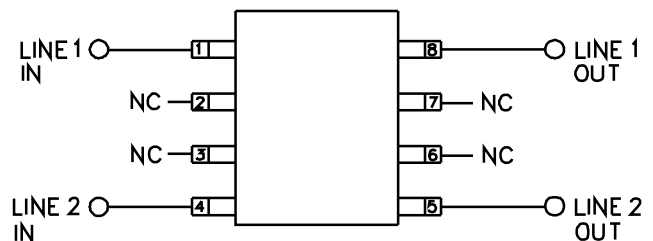

Connection for Differential Protection (Line-to-Line)

LC03-6-L on T1 Line Card Application

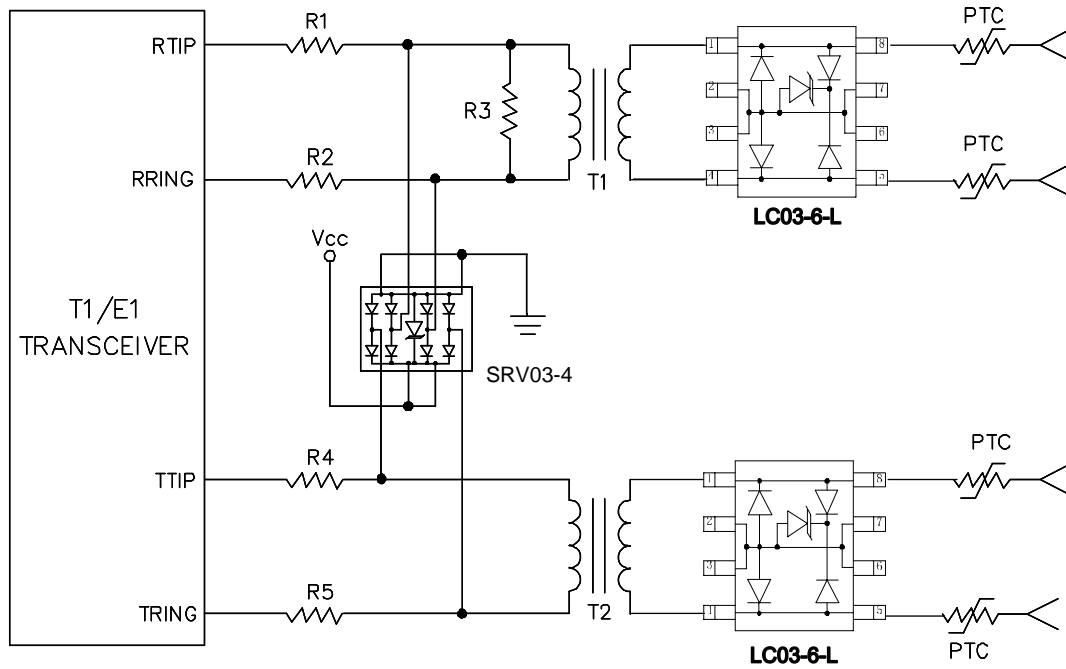

LC03-6-L on T3/E3 and STS-1 Application

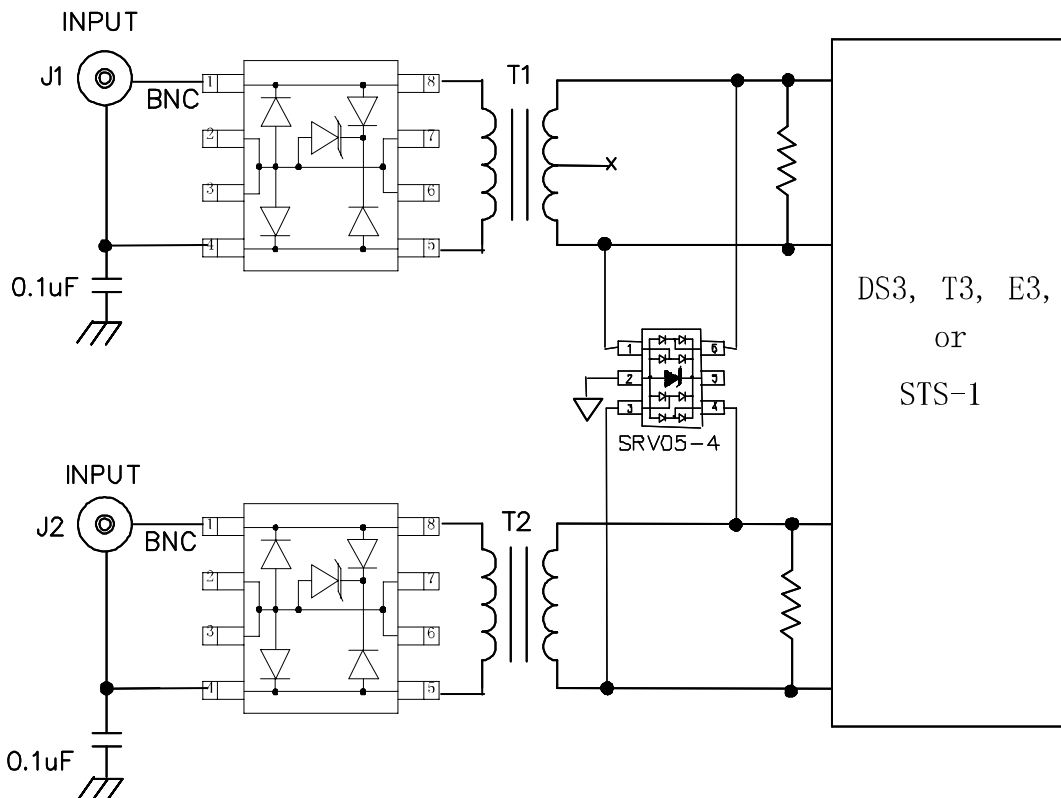

LC03-6-L on ISDN S-Interface Application

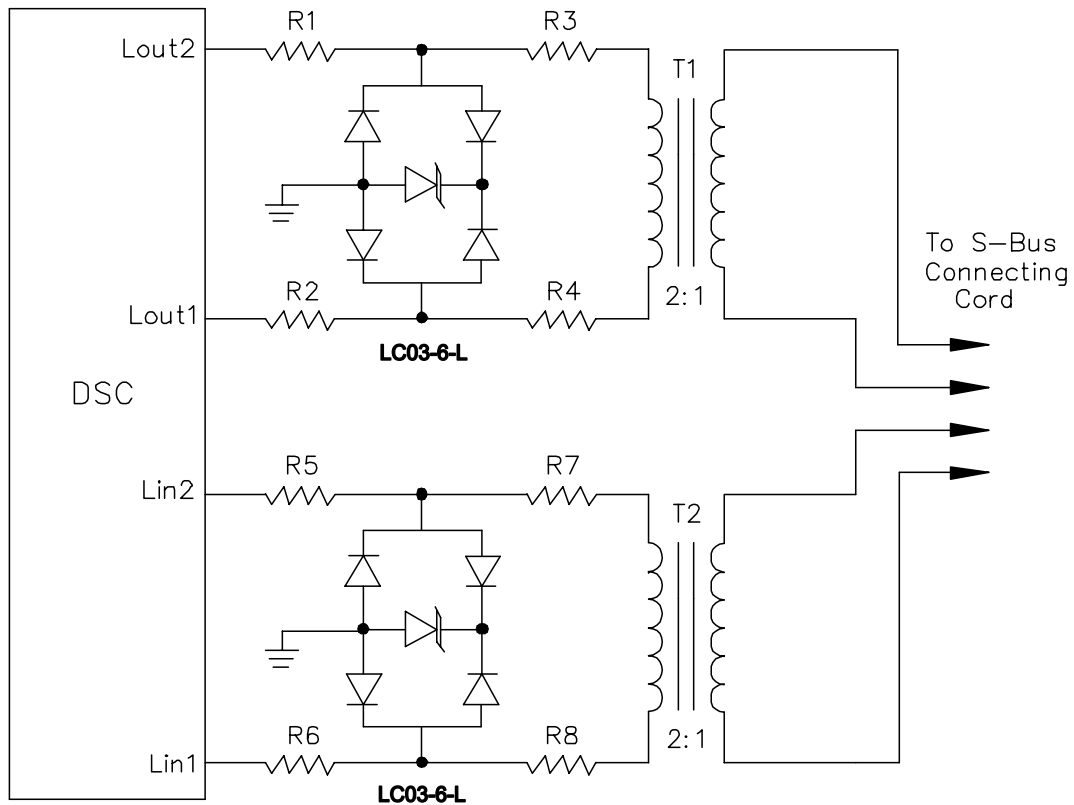

LC03-6-L on ISDN U-Interface Secondary Application

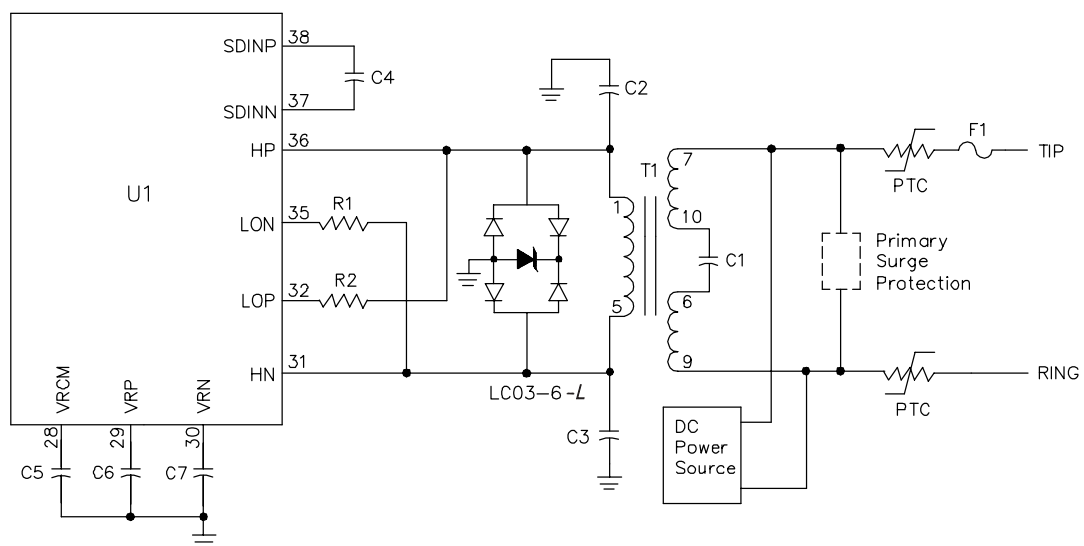

Applications Information – SPICE Model

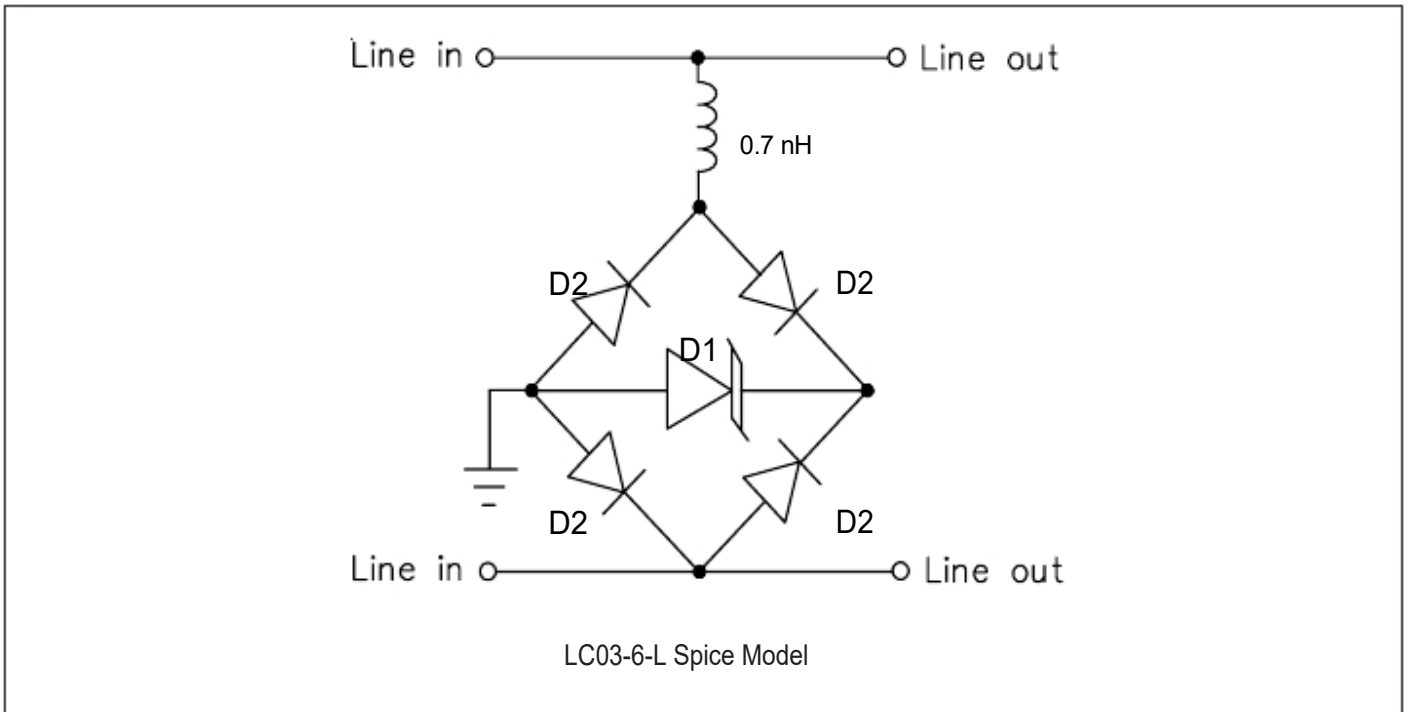

LC03-6-L Spice Parameters			
Parameter	Unit	D1 (TVS)	D2 (LCRD)
IS	Amp	1.0E-20	3.98E-13
BV	Volt	7.9	240
VJ	Volt	0.6	0.64
RS	Ohm	0.102	0.048
IBV	Amp	1E-3	1E-3
CJO	Farad	3.4e-9	8.0E-12
TT	sec	2.541E-9	2.541E-9
M	--	0.007	0.022
N	--	1.1	1.1
EG	eV	1.11	1.11

SO-8 Package Outline Drawing

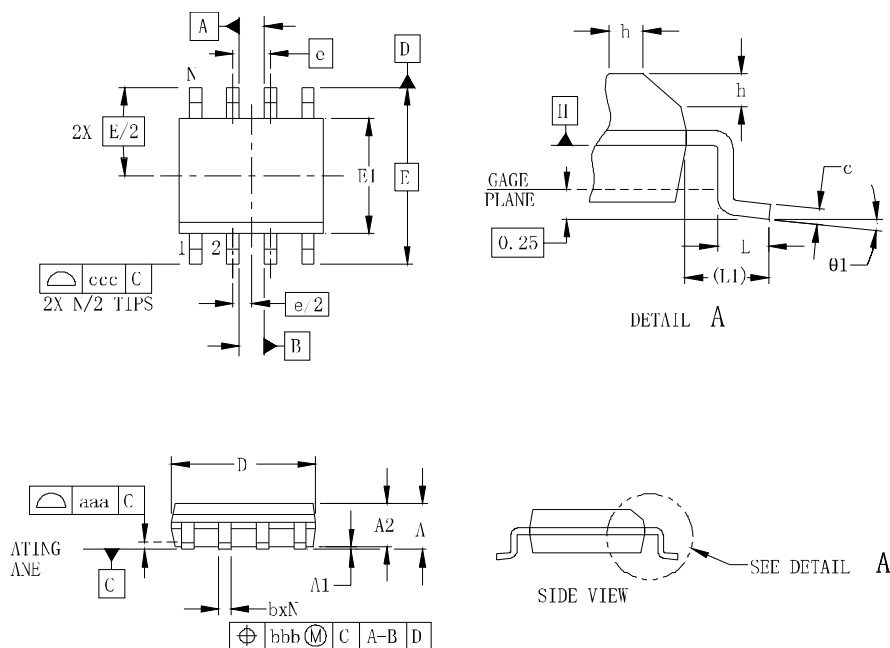

SYM	DIMENSIONS					
	MILLIMETERS			INCHES		
	MIN	NOM	MAX	MIN	NOM	MAX
A	1.35		1.75	0.053		0.069
A1	0.10		0.25	0.004		0.010
A2	1.25		1.65	0.049		0.065
b	0.31		0.51	0.012		0.020
c	0.17		0.25	0.007		0.010
D	4.80	4.90	5.00	0.189	0.193	0.197
E1	3.80	3.90	4.00	0.150	0.154	0.157
E	6.00 BSC			0.236 BSC		
e	1.27 BSC			0.050 BSC		
h	0.25		0.50	0.010		0.020
L	0.40	0.72	1.04	0.016	0.028	0.041
L1	(1.04)			(0.041)		
N	8			8		
θ1	0°		8°	0°		8°
aaa	0.10			0.004		
bbb	0.25			0.010		
ccc	0.20			0.008		

Suggested Land Pattern

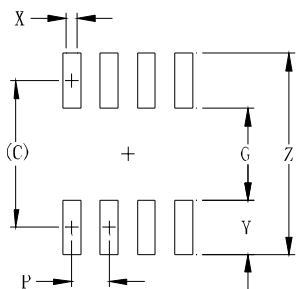

SYM	DIMENSIONS	
	MILLIMETERS	INCHES
C	(5.20)	0.205
G	3.00	0.118
P	1.27	0.050
X	0.60	0.024
Y	2.20	0.087
Z	7.40	0.291

Contact Information

Changzhou D-first Electronics CO.,Ltd.
 www.first-electronic.com
 Email: xhf@first-electronic.cn
 Phone: +86 (0519) 8817 1671

Marking Information

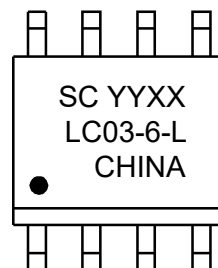

YYXX=Date Code
 Dot denotes Pin1